



# DV803<sup>NOBU</sup>

**L'esatta espressione di chiarezza e leggerezza costruttiva.**

Si pone come prodotto che predilige l'operatività; con la sua semplicità strutturale, forme minimali ed eleganti configura e personalizza gli ambienti di lavoro.

**The exact expression of clarity and lightness of construction.**

Arises as a product favouring operations; with its light design of structure added to the minimal and elegant shapes it configures and customizes any workplace.

# DV803<sup>NOBU</sup>

# LIGHTWEIGHT

## TIPOLOGIE TAVOLI DESK TYPOLOGIES



TAVOLI SCRIVANIA ALTEZZA FISSA 74 cm  
"TIPO C" - Sitting Only -  
Rif. Normativa EN 527-1:2011

FIX DESKS HEIGHT, H 74 cm  
"TYPE C" - Sitting Only -  
Norm Reference: EN 527-1:2011



TAVOLI BENCH ALTEZZA FISSA 74 cm  
"TIPO C" - Sitting Only -  
Rif. Normativa EN 527-1:2011

FIX BENCH-DESK HEIGHT, H 74 cm  
"TYPE C" - Sitting Only -  
Norm Reference: EN 527-1:2011



TAVOLI SCRIVANIA POSIZIONABILI IN ALTEZZA  
CON PULSANTE DA 65÷86 cm  
"TIPO B-D" - Sitting Only -  
Rif. Normativa EN 527-1:2011

DESKS WITH ADJUSTABLE HEIGHT BY  
PUSH-BUTTON, FROM 65÷86 cm  
"TYPE B-D" - Sitting Only -  
Norm Reference: EN 527-1:2011

# DV803

# DESIGN



TAVOLI SCRIVANIA REGOLABILI IN ALTEZZA  
3 STADI CON MANOVELLA 65÷125 cm  
"TIPO A" - Sit/Stand -  
Rif. Normativa EN 527-1:2011

HEIGHT ADJUSTABLE DESKS  
3 LEVELS WITH CRANK 65-125 cm  
"TYPE A" - Sit/Stand  
Norm Reference: EN 527-1:2011



TAVOLI BENCH REGOLABILI IN ALTEZZA  
3 STADI CON MANOVELLA 65÷125 cm  
"TIPO A" - Sit/Stand -  
Rif. Normativa EN 527-1:2011

HEIGHT ADJUSTABLE BENCH  
3 LEVELS WITH CRANK 65-125 cm  
"TYPE A" - Sit/Stand  
Norm Reference: EN 527-1:2011



TAVOLI SU RUOTE CON PIANO RIBALTABILE  
Altezza 74 cm - Profondità 70 e 80 cm

DESKS ON CASTORS WITH FOLDABLE TOP  
Height 74 cm - Depth 70 and 80 cm

# NOBU



DV803



NOBU



1

DV803-NOBU



La versione operativa in linea si contraddistingue per praticità e stile in perfetto equilibrio tra funzione e accoglienza. Con questo sistema non ci si sofferma più alla sola operatività del posto di lavoro ma si considera anche lo spazio stesso come ambiente di accoglienza per scambi di idee e relazioni. L'accostamento dei materiali usati per ante e piani gioca su toni neutri.

The inline operative version is characterized by its practicality and style in perfect balance between function and reception. With this system not only is there the sole operation of the workplace, but also the space itself is considered as a welcoming environment for exchanging ideas and social relations. The combination of materials used for doors and worktops are a play of neutral tones.



1

DV803-NOBU







DV803



NOBU





Versione direzionale della collezione. Perfetto equilibrio tra forme, materiali e destinazioni d'uso. Il direzionale pulito e rigoroso viene accompagnato dal tavolo riunione per veloci momenti di briefings. Le finiture e gli accostamenti cromatici legano armonicamente le due realtà direzionale-meeting dando a ciascuna forte carattere.

The executive version of the collection. A perfect balance of shapes and materials for intended uses. The managerial desk is clean and rigorous completed with a conference table for quick de briefings. The finishing details and colour schemes harmoniously tie the two worlds: managing and meeting thus giving each one a strong character.



Le diverse geometrie che caratterizzano l'arredo, uniscono efficienza e funzionalità vestendo lo spazio lavorativo con attenzione e puntualità.

The different geometries that characterize the furniture combine efficiency and functionality and they dress the working space with care and punctuality.











DV803

# 3



NOBU





Linee forti, chiare, definite, accostate a materiali diversi creano situazioni di benessere anche nell'ambiente di lavoro in team. Piccoli elementi di colore - sedie, poltrona, frontal panels - danno carattere alla composizione.

Strong lines, clear and defined together with different materials create situations of wellness even in the team workplace. Small colour elements - chairs, armchair, frontal panels - give character to the composition.







DV803





NOBU





Composizione a spina centrale, composta dai mobili di servizio che permettono uno sviluppo orizzontale dei componenti. Sistema semplice e cadenzato che consente configurazioni con il giusto grado di interazione e privacy.

Formation with central spine, composed of service units that allow a horizontal development of the elements. Easy and measured system allowing configurations for adequate room for interaction and privacy.





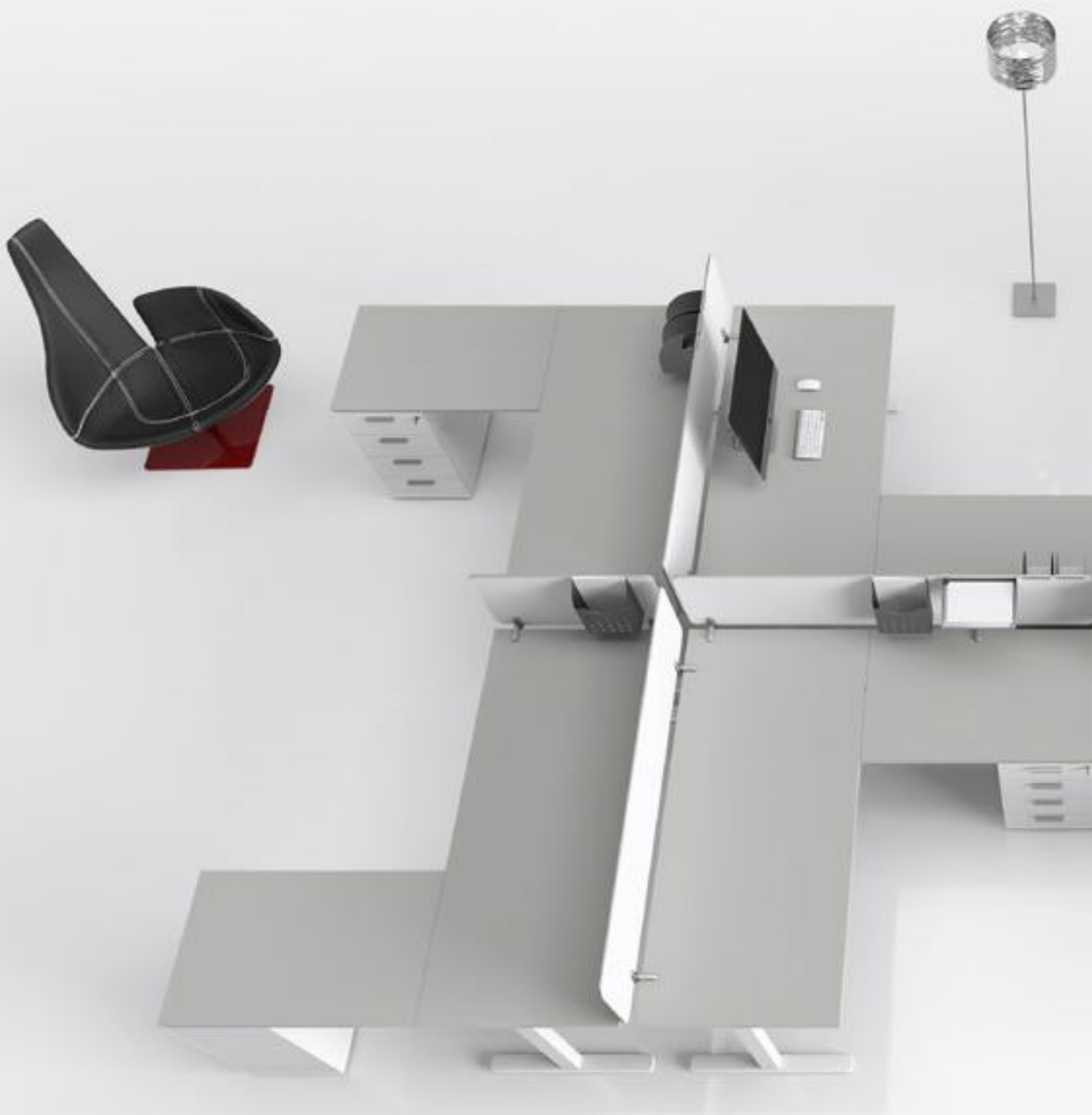

DV803

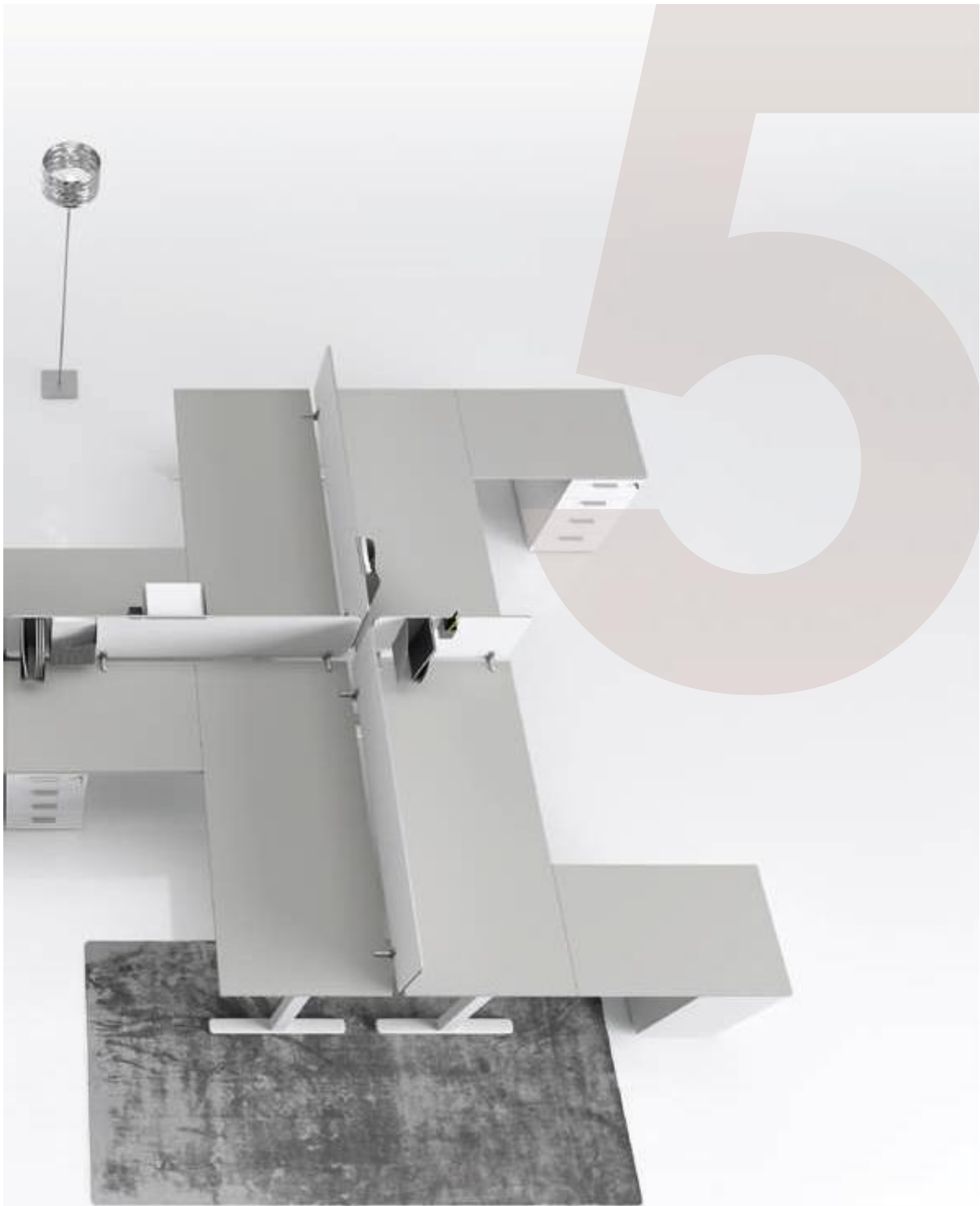

NOBU







Ogni postazione è personalizzabile tramite diversi accessori studiati per soddisfare le diverse esigenze lavorative. Mobili di servizio, cassettiere e frontal panels completano e definiscono l'organizzazione spaziale dell'area operativa.

Each location can be customized with various accessories designed to meet different work needs. Service units, pedestals and frontal panels complete and define the spatial organization of the workplace.







DV803



NOBU





Lo spazio dedicato alle relazioni, allo scambio di idee e alla pianificazione, prevede un grande tavolo con piani di testa semicirculari, dove l'attenta scelta dei materiali, impreziosisce il grande elemento d'arredo.

The space dedicated to meetings, exchange of ideas and planning is considered with a large table with semi-circular head elements, where the careful choice of materials, make the large piece of furniture precious.



DV803-NOBU







DV803



NOBU





Il sistema aggregato con piani curvi, offre l'ottimale rapporto tra ergonomia e funzionalità operativa per definire uno spazio ad alto contenuto tecnologico. Armadiature, cassettiere, accessori e frontal panels arricchiscono e completano lo spazio operativo.

The aggregated system with curved worktops, provides the optimum balance between ergonomics and operational functionality to define a space with high-tech contents. Storage units, pedestals, accessories and frontal panels enrich and complete the operational space.



La collezione include la possibilità di regolare in altezza il piano di lavoro da un minimo di 65 ad un massimo di 86 cm. Attraverso la pressione di un semplice pulsante, è quindi possibile selezionare l'altezza più corretta per l'utente.

The collection includes the possibility to adjust the height of the desk worktop from a minimum of 65 to a maximum of 86 cm. Through the pressure on a simple button it is possible to select the most appropriate height for the end user.



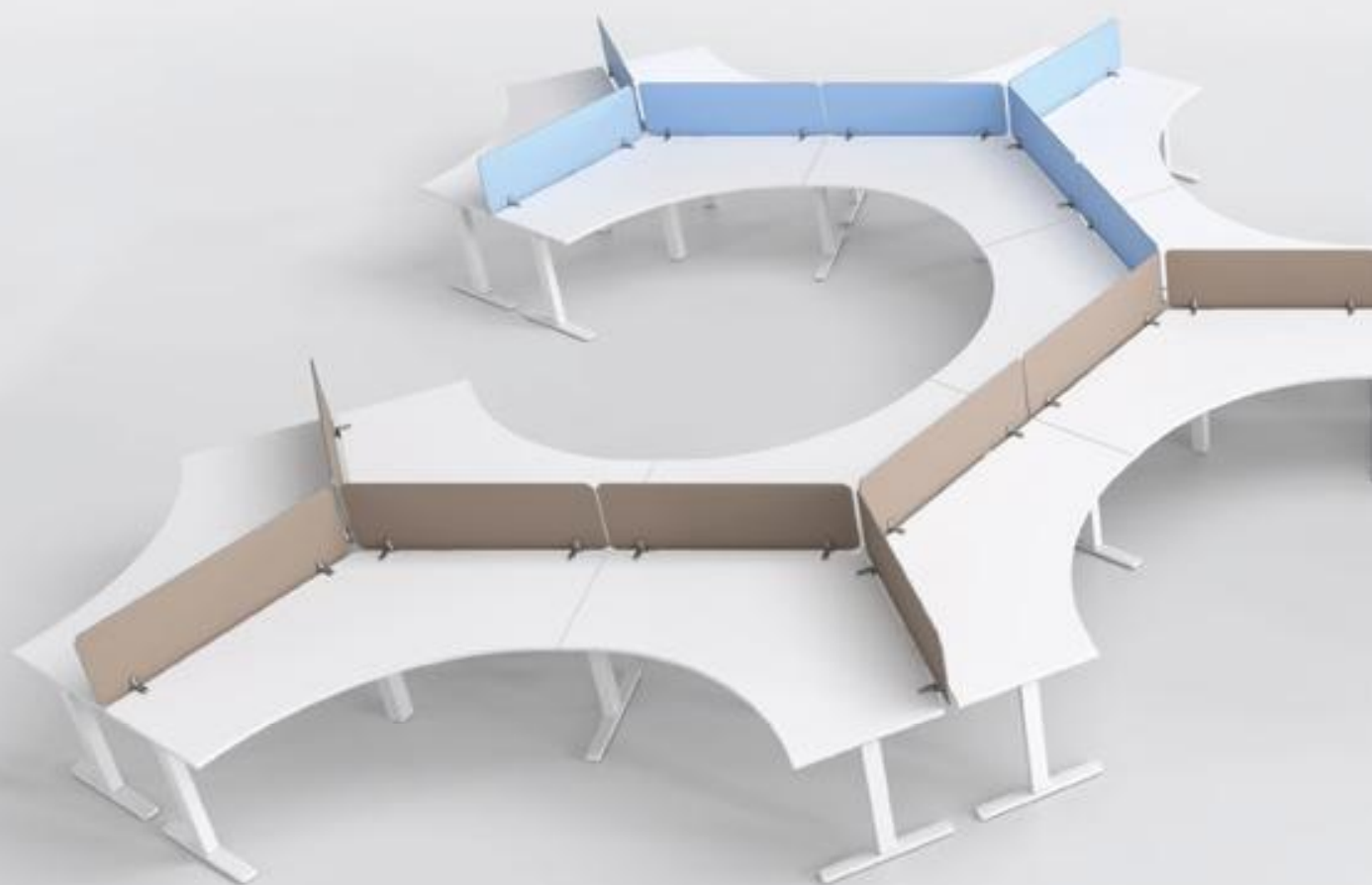

DV803



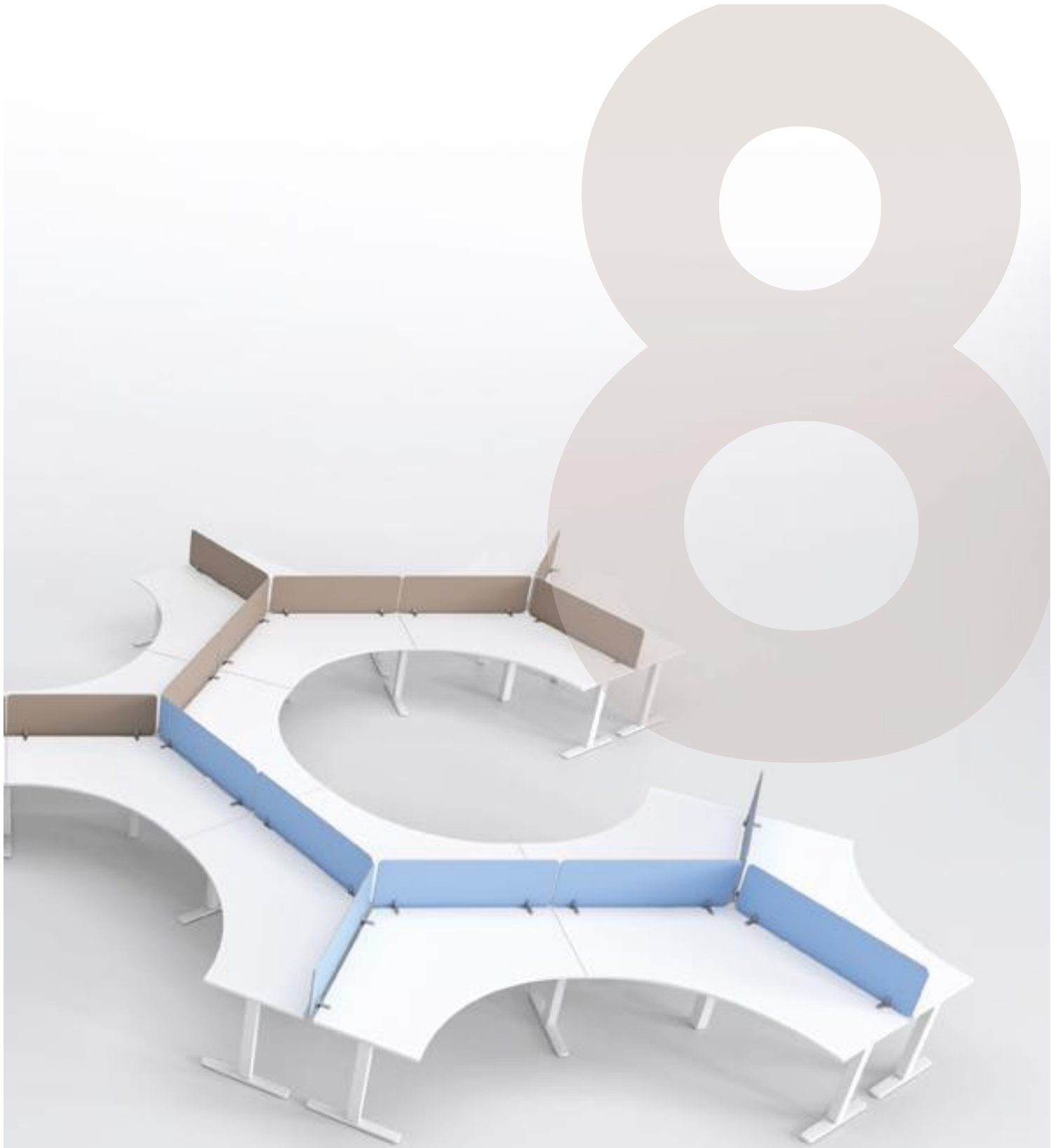

NOBU





L'open space viene organizzato in modo armonico, funzionale, coordinato ma anche giocoso. Il taglio del piano di lavoro a 120° consente molteplici soluzioni distributive. All'utilizzatore finale la soluzione che lo soddisfa pienamente.

The open space is arranged in a harmonious, functional, coordinated but also playful way. The 120° shaped worktop allows multiple distribution solutions. The solution that fully satisfies the end user.



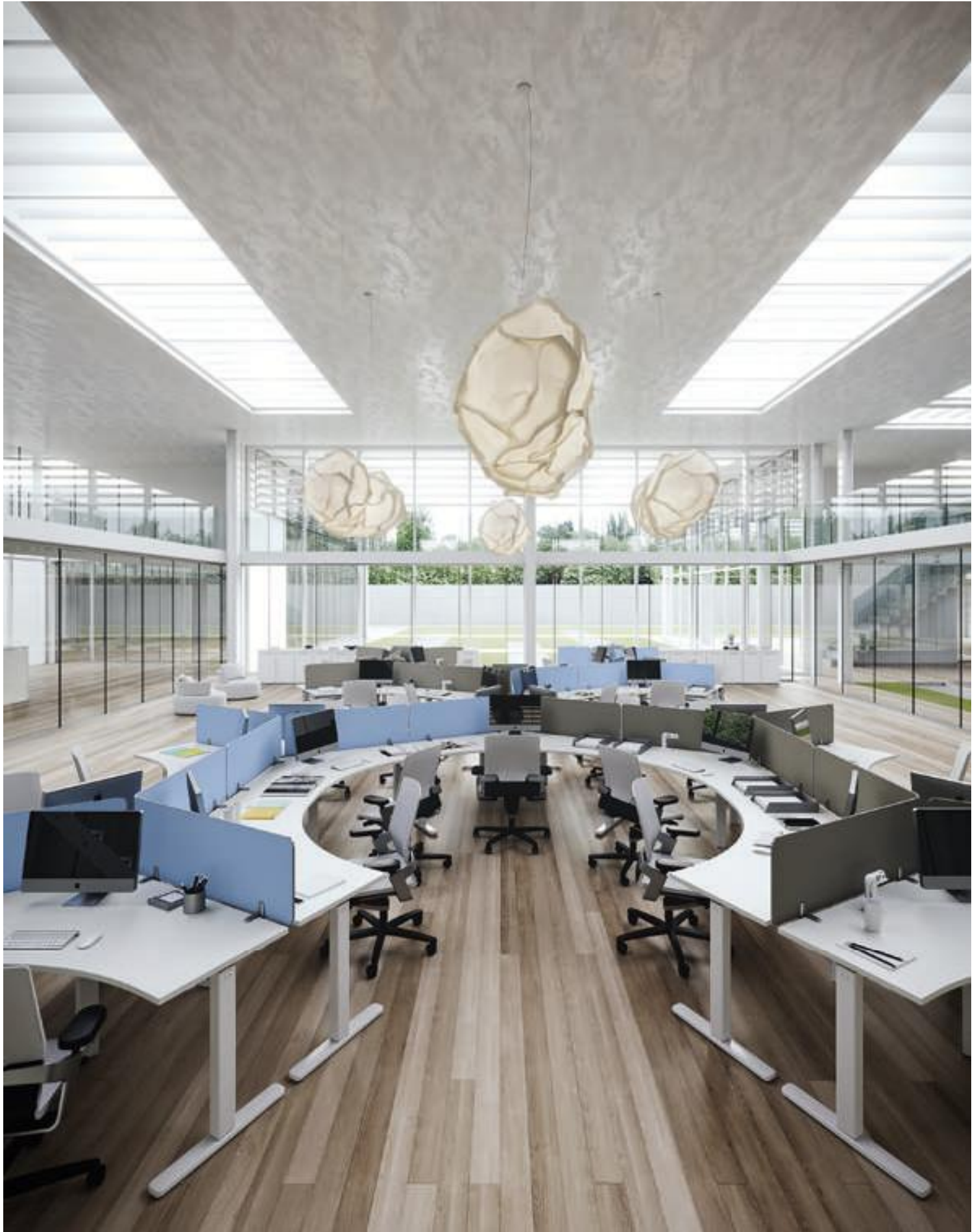



DV803

# 9

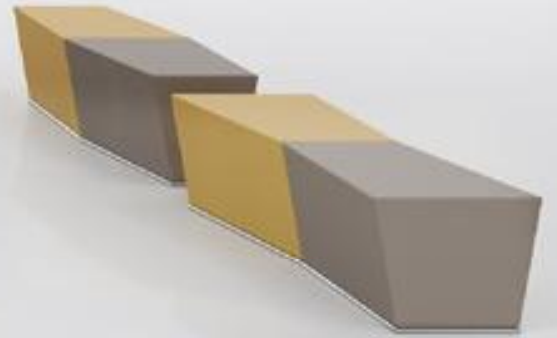

NOBU







Funzionale operatività di gruppo, in cui postazioni di lavoro contrapposte integrano, con rigore e simmetria, ampie scrivanie con tavoli in allungo. Caldo e confortevole l'abbinamento cromatico del rovere tabacco dei piani di lavoro con il bianco opaco delle strutture metalliche. Cassettiere e nuovi contenitori portaoggetti sospesi, porta CPU, frontal panel personalizzano con eleganza il posto di lavoro. Il centro dell'ambiente viene attraversato da attualissimi "Standing Tables", composti su richiesta; utilizzati da un lato per il lavoro in piedi o con sgabello e nel lato opposto sono integrati ai nostri contenitori con ante.

Functional teamwork, in which opposing workstations integrate, with rigor and symmetry, large desks with extension tables. The colour combination of worktops in tobacco oak with the matt white of metal structures is warm and comfortable. Pedestals and new suspended storage units, CPU holders, frontal panels personalize with elegance the workplace. The environment centre is crossed by very typical "Standing Tables", composed on request; used on the one side for the standing work or with stools, on the opposite side they are integrated with our storage units with doors.



Punti di vista concentrati sulle diverse zone e tipologie di arredi utilizzati, mettono in evidenza i dettagli degli "Standing Tables" e delle scrivanie contrapposte. Lungo le pareti si trovano contenitori alti con ante, vani a giorno e pratici Lockers per la custodia di effetti personali.

Points of view focused on the different areas and types of furniture used. They bring out the details of the "Standing Tables" and opposed desks. Along the walls are high cabinets with doors, open elements and practical "Lockers" for storage of personal belongings.





DV803

# 10



NOBU





Vista panoramica di un "open space" arredato con tavoli bench e scrivanie regolabili in altezza con manovella secondo le attuali normative. Sullo sfondo i tavoli pieghevoli utilizzabili all'occorrenza.  
In evidenza i nuovi frontal panels in tessuto con profilo perimetrale in metallo predisposto per l'aggancio di accessori vari.

Panoramic view of an "open space" furnished with bench-desks and height-adjustable desks with a crank system, in accordance with current regulations. In the background folding tables available in case of need.  
Highlights of the new fabric frontal panels with metal edge profile prepared for the integration of various accessories.



La serie comprende anche funzionali e utili tavoli su ruote con piano ribaltabile che gira azionando la maniglia sottopiano. Disponibili in diverse dimensioni e, su richiesta, si possono accessorizzare integrando leggeri modesty panel in tessuto tecnico, appositi fermacavi sottopiano oppure sistemi di aggancio per collegare all'occorrenza con estrema velocità i tavoli tra di loro.

The series also includes functional and useful folding tables on castors, where the worktop turns by operating the handle under the worktop. Available in different sizes, on request, they can be accessorized with modesty panel in technical fabric, under counter cable holders, or hooking systems to quickly connect tables between them, if necessary.





# PLUS&DETAILS



Trave metallica telescopica, canalizzata con clips bloccacavi  
Telescopic metal beam, ducted, with cable clamps



Canalizzazione per tavoli a due scrivanie contrapposte  
Wire management for bench desks



Binario con clips fermacavi, per raccordi  
Channel with cables-holder clips, for connection elements



Canale passacavi per gamba  
Leg cable channel



Passacavi verticale a spirale  
Spiral cable duct



Frontal panel in melaminico sp. 1 cm, con morsetti per piano  
Frontal panel in melamine 1 cm thick, with clamps for desk



Frontal panel in vetro sp. 0,8 cm, con morsetti per piano  
Frontal panel in glass 0.8 cm thick, with clamps for desk



Frontal panel in melaminico sp. 3 cm, con morsetti per piano  
Frontal panel in melamine 3 cm thick, with clamps for desk



Frontal panel rivestito in tessuto con telaio perimetrale metallico, per piani o bench  
Frontal panel covered in fabric with external metal frame, for desks or bench



Accessori in lamiera per frontal panel in melaminico - Sheet metal accessories for melamine frontal panel



Dettaglio piano raggiato  
Detail of rounded corner



Dettaglio piano a spigolo  
Detail of sharp corner



Porta CPU sospeso  
Hanging CPU holder



Porta CPU su ruote  
CPU holder on castors